

公差/General tolerances(mm)		公差/General tolerances(mm)	
0	>3	>18	>315
~	~	~	~
3	6	18	315
~	~	~	~
±0.12	±0.18	±0.22	±0.26
±0.31	±0.37	±0.57	±0.80
±0.93	±1.05	±1.15	±1.60
±2.20	±2.50	±2.50	±2.50
0.1/10	±Z		

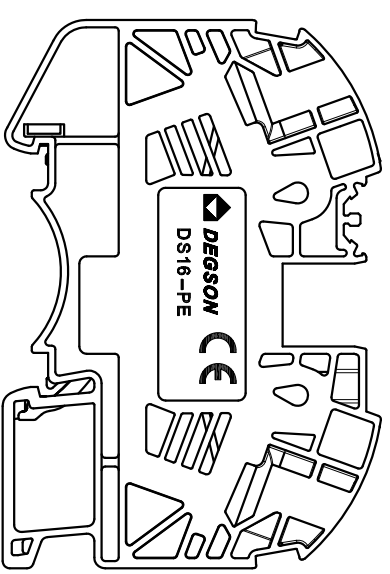
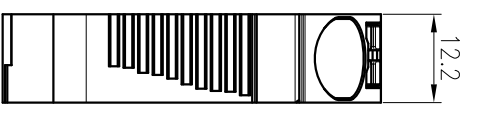
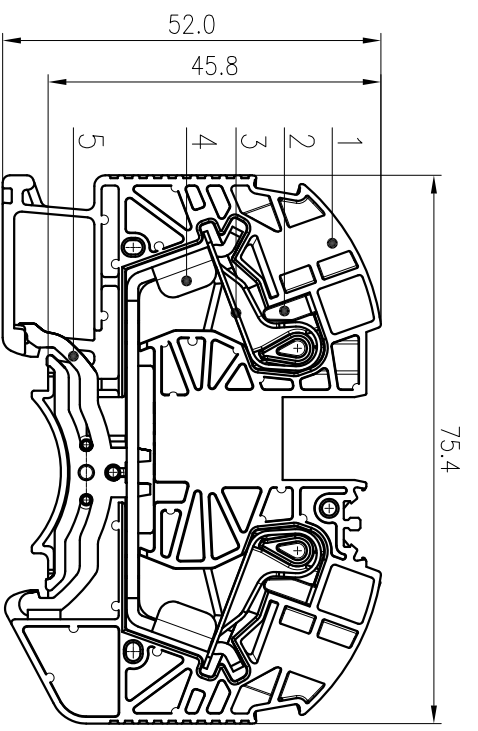
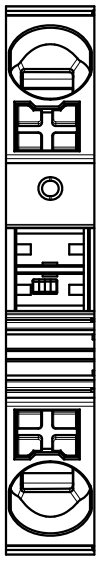

UL 标准/UL Standard:	B	C	D
额定电压/电流/Rated Voltage(V)/Current(A)	/	/	/
EC 标准/IEC Standard:	/	/	/
过压类别/Overvoltage Category/污染等级/Pollution Degree	III/3	III/2	II/2
额定电压/电流/Rated Voltage(V)/Current(A)	/	/	/
额定脉冲电压(KV)/Rate Impulse Voltage(KV)	8	/	/
导线范围(硬线和软线)/Wire Range(rigid and flexible)(mm ² /AWG)	0.5~16,25(Sol)/20~4		
间距/Pitch(mm)	10.2		
剥线长度/Stripping length(mm)	18		
使用温度范围/Operating temperature(°C)	-40~+105		
符合RoHS环保要求/Conform to RoHS	Yes		

SURFACE: /

DEGSON 宁波高松电子有限公司
NINGBO DEGSON ELECTRICAL CO., LTD

NAME: DS16-PE-01P-1C-00A(H)

MAT NO.:	/		
STATUS:	/		
APPD:	Li GL 2020.06.01		
CHKD:	Mao J 2020.06.01		
DRAFT/ Huang S 2018.10.23			
DRAWING NO.:	DS16-PE-C01	REV	D0-2
TYPE: CUSTOMER DRAWING	SCALE: 1:1	SHEET	1/1

ITEM	NAME OF PART	MATERIAL	NOTES
1	Housing	PA66	UL94 V-0
2	Button	PA66-GF	UL94 V-0
3	Spring	Stainless steel	
4	Current Carrier	Copper	Sn plated
5	Grounding	Copper alloy	Sn plated

REV	ECN	DESCRIPTION	DRAFT	DATE